



- ✓ *SN12PT*
- ✓ *SN10PT*
- ✓ *SN8.0PT*
- ✓ *SN6.0PT*
- ✓ *SN5.0PT*
- ✓ *SN4.0PT*
- ✓ *SN3.0PT*

User Manual

SN3.0-12PT



Sineng Electric Co., Ltd.

Version: V1.0

This manual is applicable to the following Sineng PV inverter models:

Mode	Rated power
SN12PT	12kW
SN10PT	10kW
SN8.0PT	8kW
SN6.0PT	6kW
SN5.0PT	5kW
SN4.0PT	4KW
SN3.0PT	3KW

The symbols used in this manual indicate different usage, as described in the following table. Different symbols can be used in combination.

Symbol	Description
	This symbol indicates a warning sign that needs to be noticed.
	This symbol indicates that there is a danger of electric shock, which may cause personal injury.
	This symbol indicates that special attention must be paid due to high hazard risks.

This manual will be updated from time to time due to product upgrades and other reasons without prior notice.

The copyright of this user manual belongs to Sineng Electric Co., Ltd. and shall not be reproduced without authorization.

Safety precautions

This manual describes important precautions and instructions that must be followed during the operation and maintenance of the SN series PV inverters. Before installation, please read this manual carefully.



Warning

- *Please install the inverter in strictly accordance with the instructions in this manual. Otherwise, it may cause damage to the equipment or endanger the personal safety of the operator.*
- *The installation, commissioning, and maintenance of the inverter must be implemented by the manufacturer or designated agent. Otherwise, it may endanger the personal safety and cause equipment failure. The damage to the equipment caused by violations of these precautions is not covered by the warranty.*
- *The operator shall be fully familiar with the relevant standards and operating safety regulations of the corresponding regions/countries, and perform operations in accordance with relevant regulations.*
- *The SN series inverter meets the limit values in Class B of the EMC standard and is applicable to residential and commercial environments.*
- *Before performing any operations on the inverter, read this manual and the safety signs and instructions on the surface of the inverter carefully.*



Danger

- *The inverter must be reliably grounded. The grounding of the equipment must comply with local electrical codes. Otherwise, it will endanger the personal safety of the operator.*
- *When the PV array is exposed to light, the port has high DC voltage. Do not directly touch the DC port and the terminal directly connected to the DC port without protective measures or without confirming the voltage, so as to avoid personal injury. Obvious signs and protective measures must be used when necessary!*
- *There are dangerous voltages inside the inverter during normal operating. Do not disassemble the internal cover plate of the inverter without authorization or permission to avoid damage to the equipment or personal injury.*
- *There are energy storage components inside the inverter. After the inverter is completely powered off, wait for no less than 5 minutes before proceeding with subsequent operations.*

Contents

Chapter 1	Product Overview	1
1.1	PV Power Generation System	1
1.2	Inverter Appearance	2
1.2.1	Appearance and Dimensions	2
1.2.2	Description of Indicators on the Panel	3
1.2.3	Display and Button	3
1.2.4	Nameplate and Label	5
1.3	Main Circuit Structure	6
Chapter 2	Inverter Installation	7
2.1	Storage Before Installation	7
2.2	Handling and Unpacking	7
2.3	Inverter Installation	8
2.3.1	Installation Tools	8
2.3.2	Installation Environment Requirements	8
2.3.3	Installation Angle	9
2.3.4	Installation Space	9
2.3.5	Installation Requirements	11
Chapter3	Electrical Connections	14
3.1	Connecting the Ground Cable	15
3.2	Connecting the AC Cable	16
3.2.1	AC Circuit Breaker Selection	16
3.2.2	AC Cable Connection	17
3.3	Connecting the DC Cable	19
3.4	Installing the Communication Module	20

3.5 Installing the Communication Cable	21
3.6 Inspection after Installation	23
Chapter 4 Inverter Operations	24
4.1 Power-On/Off Operations	24
4.1.1 Power-On Operation	24
4.1.2 Power-Off Operation	24
4.2 Cable Disconnection Operation	25
Chapter 5 Events and Alarms	26
5.1 Event Information	26
5.2 Alarm Information	26
Chapter 6 Product Specifications	28
6.1 Application Standards	28
6.2 Conventional parameters	28
6.3 Electrical Characteristics (DC Input)	28
6.4 Electrical Characteristics (AC Output)	29
6.5 Electrical Characteristics (Protection Characteristics)	30
6.6 Electrical Characteristics (System Characteristics)	30
Chapter 7 Product Maintenance	31
7.1 Periodic Maintenance	31

Overview of Manual

Before unpacking and installing the product, please read this manual thoroughly, which contains the following chapters:

Symbol Conventions: This chapter summarizes various symbols that appear in the manual and explains the symbols for better reading.

Safety Precautions: This chapter describes precautions that require attention before operation.

Chapter 1 Product Overview: This chapter briefly introduces the PV inverter and PV power generation system.

Chapter 2 Inverter Installation: This chapter introduces the storage conditions, handling instructions and installation instructions required for the reliable running of the inverter.

Chapter 3 Cable Connection: This chapter describes the external power cable and communication cable used to connect the inverter to external equipment.

Chapter 4 Inverter Operation: This chapter introduces the human machine interface, power-on/off operation and disconnection operations.

Chapter 5 Events and Alarms: This chapter provides a list of events and alarms of the inverter.

Chapter 6 Product Specifications: This chapter describes the product specifications of SN series PV inverters.

Chapter 7 Product Maintenance: This chapter introduces inverter maintenance, including periodic maintenance and daily maintenance.

After-sales Service Information: This chapter provides the contact information for after-sales service of the product.

Chapter 1 Product Overview

1.1 PV Power Generation System

SN series inverters are string PV inverters without transformers. They are used to convert the DC energy of PV panels into AC electrical energy, which can be delivered to the power grid directly or through grid-connected transformers.

The following figure shows the schematic diagram of the PV power generation system.

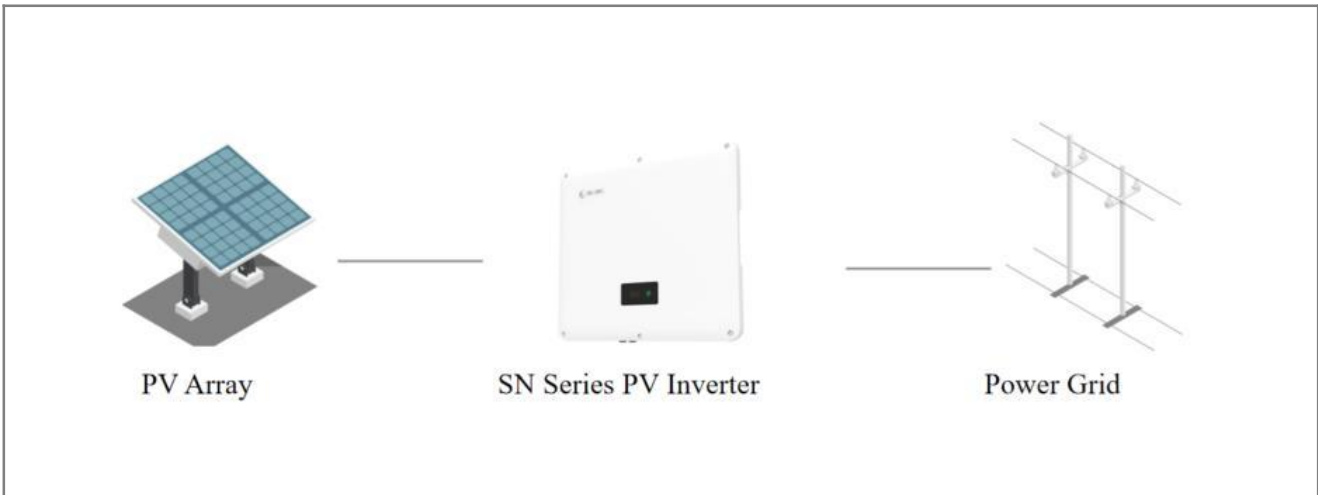

Figure 1-1 Composition of the PV power generation system

The power grids supported by SN12PT/SN10PT/SN8.0PT/SN6.0PT/SN5.0PT/SN4.0PT/SN3.0PT are TN-S, TN-C, TN-C-S, TT and IT, as shown in Figure 1-2.

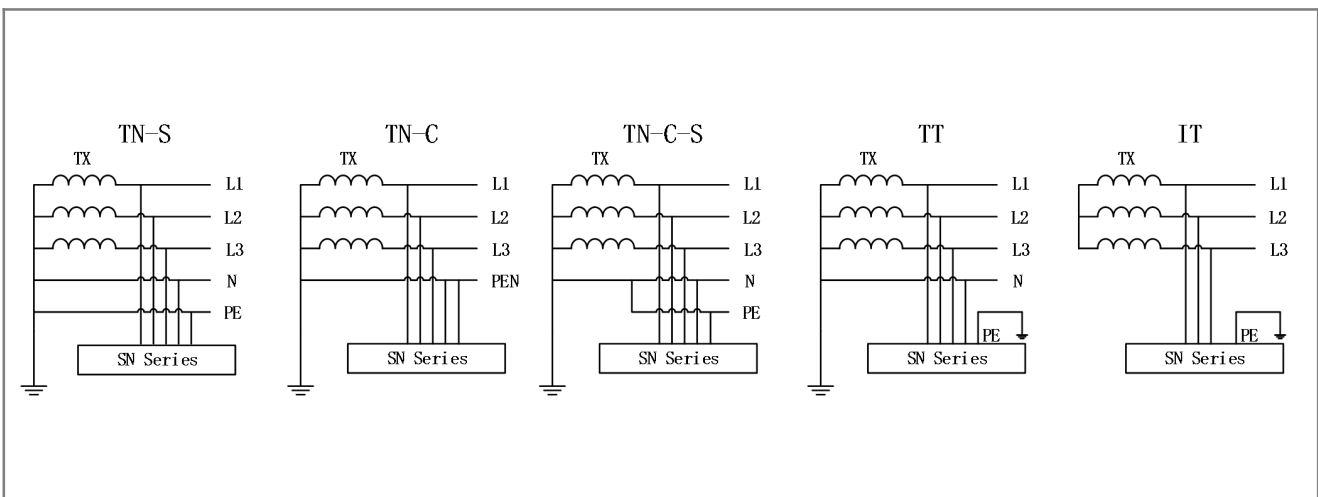

Figure 1-2 Power grids supported by SN series inverter

1.2 Inverter Appearance

1.2.1 Appearance and Dimensions

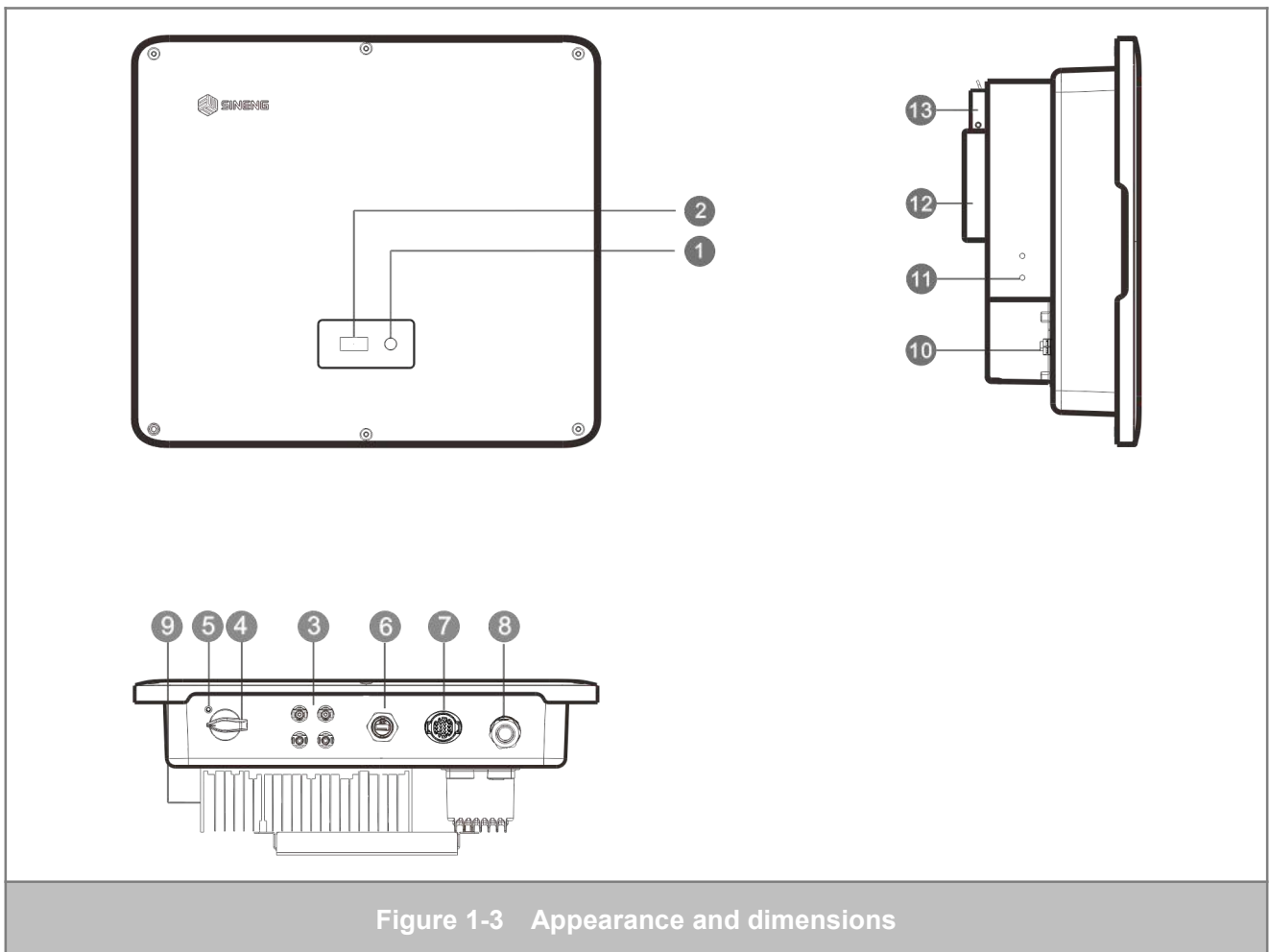

Figure 1-3 Appearance and dimensions

SN	Item	SN	Item
①	Button* /Indicator	②	Display*
③	DC terminal	④	DC switch
⑤	DC switch locking screw hole	⑥	USB interface
⑦	Communication interface	⑧	AC interface
⑨	Heat sink	⑩	Waterproof ventilation valve
⑪	Secondary grounding	⑫	Mounting backplane
⑬	Hanging plate	⑭	

Table 1-1 Appearance structure of the inverter

*Buttons and display are optional accessories, which are subject to the actual product received.

1.2.2 Description of Indicators on the Panel

Color	Status	Description
Green	Slow blinking, on for 1s and off for 1s	Standby
	Fast blinking, on for 0.25s and off for 0.25s	Self-test upon startup
	Steady on	Operating
Blue	Steady on	Updating...
Red	Slow blinking, on for 1s and off for 1s	AC power disconnected, DC power energized
	Steady on	Fault
Off		AC and DC power disconnected, equipment shutdown

Table 1-2 Description of indicators on the panel

1.2.3 Display and Button [Display and buttons are optional accessories, which are subject to the actual product received]

- **Description**

Welcome screen: This screen lasts for 3s and is only displayed when the equipment is powered on. The system directly jumps to the main screen after 3s.

Main screen: This is an animation screen displaying the time, panel, inverter, power grid, AC output power, DC output power, power factor and other information.

Other screens display the following information: PV voltage, PV current, PV power, AC voltage, AC current, AC frequency, power generation capacity, operating status, fault information, serial number, safety regulation, and modbus address

Page count: Thirteen pages in total

- **Button**



The main function of the button is to switch the display page, which does not need to be configured. The screen turns black after 10 minutes if there is no action. When there is a button action, the system enters the main screen (or the page before the black screen).

- **Language**

The display language follows the safety regulations. If the safety regulations are stipulated by China, the display language is Chinese. Otherwise, the display language is English.

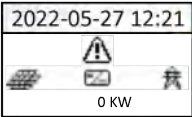
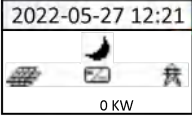
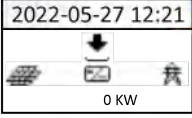
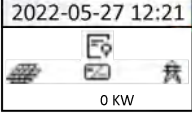
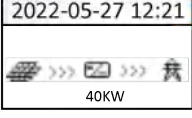
The following table describes the information displayed on the page.

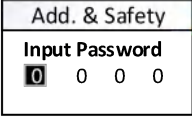
Display	Description								
	The inverter has a fault alarm.								
	The inverter is in the standby state.								
	The inverter is in the software update state.								
	The inverter is in the startup self-test state.								
	The inverter is in the normal operating state.								
<table border="1" data-bbox="288 954 480 1070"> <thead> <tr> <th colspan="2">PV1</th> </tr> </thead> <tbody> <tr> <td>Vol:</td> <td>225.9V</td> </tr> <tr> <td>Cur:</td> <td>5.9A</td> </tr> <tr> <td>Pow:</td> <td>28.5kW</td> </tr> </tbody> </table>	PV1		Vol:	225.9V	Cur:	5.9A	Pow:	28.5kW	When string current detection board is configured, the page displays the PV input information.
PV1									
Vol:	225.9V								
Cur:	5.9A								
Pow:	28.5kW								
<table border="1" data-bbox="288 1099 480 1216"> <thead> <tr> <th colspan="2">MPPT1</th> </tr> </thead> <tbody> <tr> <td>Vol:</td> <td>225.9V</td> </tr> <tr> <td>Cur:</td> <td>5.9A</td> </tr> <tr> <td>Pow:</td> <td>28.5kW</td> </tr> </tbody> </table>	MPPT1		Vol:	225.9V	Cur:	5.9A	Pow:	28.5kW	When string current detection board is not configured, the page displays the MPPT input information.
MPPT1									
Vol:	225.9V								
Cur:	5.9A								
Pow:	28.5kW								
<table border="1" data-bbox="288 1245 480 1361"> <thead> <tr> <th colspan="2">AC-R</th> </tr> </thead> <tbody> <tr> <td>Vol:</td> <td>225.9V</td> </tr> <tr> <td>Cur:</td> <td>5.9A</td> </tr> <tr> <td>Freq:</td> <td>55.01Hz</td> </tr> </tbody> </table>	AC-R		Vol:	225.9V	Cur:	5.9A	Freq:	55.01Hz	This page displays the AC output information by phase, including voltage, current, and frequency.
AC-R									
Vol:	225.9V								
Cur:	5.9A								
Freq:	55.01Hz								
<table border="1" data-bbox="288 1391 480 1507"> <thead> <tr> <th colspan="2">Energy Info</th> </tr> </thead> <tbody> <tr> <td>Today:</td> <td>0kWh</td> </tr> <tr> <td>Total:</td> <td>0kWh</td> </tr> </tbody> </table>	Energy Info		Today:	0kWh	Total:	0kWh	Power generation capacity.		
Energy Info									
Today:	0kWh								
Total:	0kWh								
<table border="1" data-bbox="288 1536 480 1653"> <thead> <tr> <th colspan="2">Error</th> </tr> </thead> <tbody> <tr> <td>ID:</td> <td>21</td> </tr> <tr> <td colspan="2">Device Fault</td> </tr> </tbody> </table>	Error		ID:	21	Device Fault		Fault code and fault name		
Error									
ID:	21								
Device Fault									
<table border="1" data-bbox="288 1682 480 1798"> <thead> <tr> <th colspan="2">SN</th> </tr> </thead> <tbody> <tr> <td colspan="2">30007000123457</td> </tr> <tr> <td colspan="2">8912</td> </tr> </tbody> </table>	SN		30007000123457		8912		SN information		
SN									
30007000123457									
8912									
<table border="1" data-bbox="288 1827 480 1944"> <thead> <tr> <th colspan="2">Add. & Safety</th> </tr> </thead> <tbody> <tr> <td colspan="2">1</td> </tr> <tr> <td colspan="2">NB/T32004-2018</td> </tr> </tbody> </table>	Add. & Safety		1		NB/T32004-2018		The first line shows the communication address. The second line displays the safety regulations information.		
Add. & Safety									
1									
NB/T32004-2018									

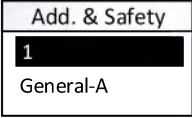
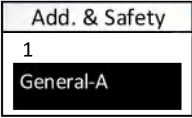
Display	Description
	When you press and hold the button in the Equipment Address and Safety Regulations page, the system displays "Please enter the password". The password is 0100. The cursor indicates that the digit can be changed. You can press the button to change the password, and each digit can be switched from 0 to 9. You can also press and hold the button to move the cursor. When the cursor is in the fourth digit position, press and hold the button to confirm the input password.
	When an incorrect password is input, the system prompts "Incorrect password". Press the button to exit the "Please enter the password" page. Then, press and hold the button to enter this page again.
	When a correct password is input, the system enters the settings page. When the cursor is in the second line (equipment address), you can press the button to switch the equipment address from 1 to 32. You can press and hold the button to confirm the settings and switch to the page for safety regulations settings.
	When the cursor is in the third line (safety regulations), you can press the button to switch the safety regulation standards. You can press and hold the button to confirm the settings and exit the settings page.

1.2.4 Nameplate and Label



SN	Description	SN	Description
①	Trademark and product information	②	Product Specifications
③	Product identification	④	SN code
⑤	Origin of production and information		

Table 1-3 Description of nameplate (The SN5.0PT as an example)







Icon	Item	Description
	Danger warning	The inverter is a power electronic product and has potential risks, especially after it is powered on. It must be operated by professional personnel with safety protection measures taken.
	Warning mark	
	Burning warning	When the inverter is running, the surface (especially the radiator part) has a high temperature. Do not touch it directly to avoid burns.
	Discharge delay mark	The inverter can be discharged to a safe voltage in 5 minutes after it is powered off. Then, the professional personnel can perform other operations.
	User Manual mark	Professional personnel should refer to the User Manual for the installation or maintenance of the inverter.
	EU WEEE mark	If you intend to discard this product, you must send it to an appropriate place for recovery and recycling. The product must not be treated as domestic waste.
	CQC certification mark	This product has passed the NB/T 32004 certification of China Quality Certification Center (CQC).

Table 1-4 Description of marks (The SN5.0PT as an example)

1.3 Main Circuit Structure

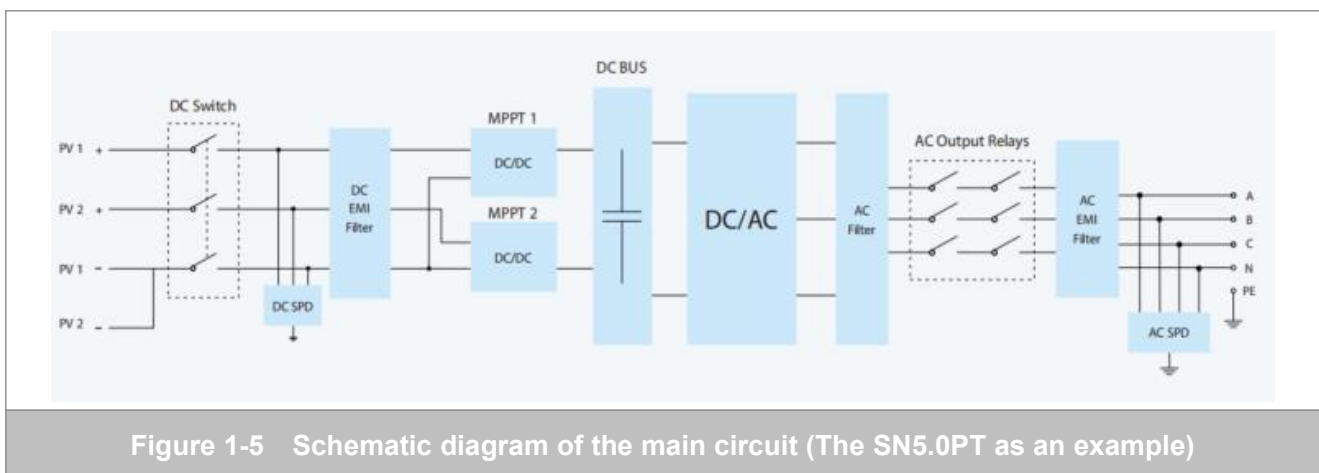

Chapter 2 Inverter Installation

This chapter introduces the on-site environmental conditions required for storage and reliable running of the inverters, installation steps, and other related instructions.

2.1 Storage Before Installation



Warning

- *The inverters must be stored indoors, and the package of the inverters must be intact. It is strictly prohibited to store the inverters without packaging. Otherwise, Sineng shall not assume any liability for the damage to the inverters, the shortening in service life or other losses caused by such storage conditions.*
 - *No more than eight inverters should be stacked together! It is strictly prohibited to store the inverter horizontally or upside down!*
 - *The inverters should be stored in a temperature range of -40 °C to 70 °C, and the relative humidity should be 0 to 100% (non-condensing).*
-

2.2 Handling and Unpacking



Warning

- *Ensure that the inverter packaging is intact and undamaged before handling! If the packaging is damaged, please stop subsequent operations! In such a case, please contact Sineng or shipping company.*
 - *Please carefully observe the instructions and warning signs on the inverter packaging before working!*
 - *Keep balance when disassembling and handling the inverters to prevent personal injury caused by the falling of the inverters.*
 - *When handling the inverter, please hold the handle position at the bottom of the inverter and the side position of the main radiator near the top. Avoid hitting other objects with the top or bottom radiator, so as not to damage the inverter housing and internal components, and avoid squeezing and scratching the operator. Remember not to hold the top radiator while handling the inverter!*
 - *When the inverter is placed on the ground, cushion materials such as foam or paper should be placed on the bottom of the inverter to avoid damage to the housing.*
-

Unpack the inverter according to the steps in Figure 2-1, and place the inverter on a flat place to prevent the inverter from toppling and prevent the radiator from collision.

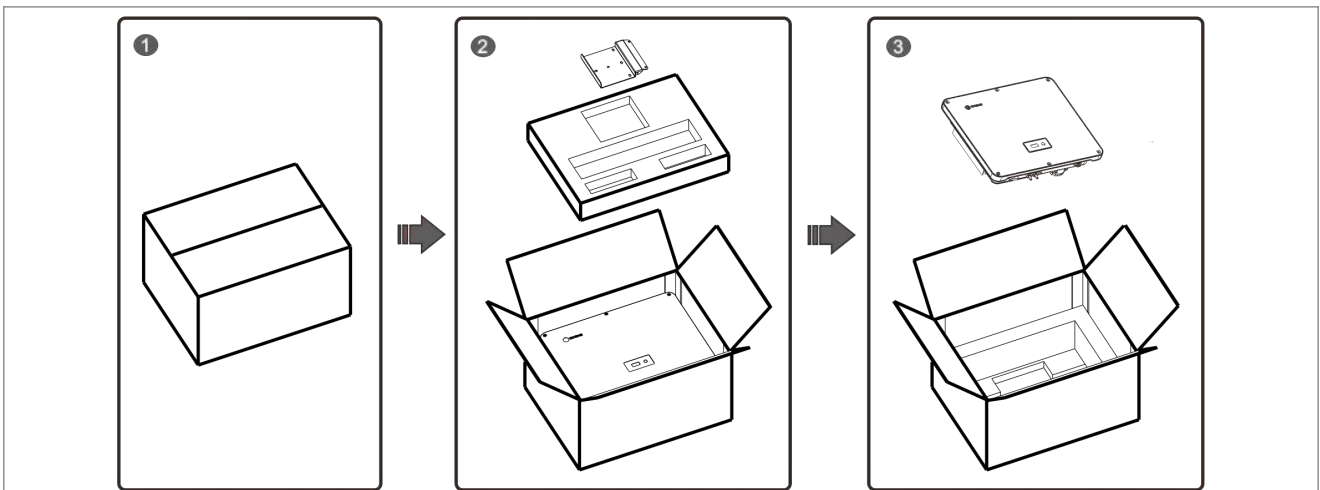

Figure 2-1 Schematic diagram of unpacking the SN series inverter

2.3 Inverter Installation



Warning

- Ensure that the inverter packaging is intact and undamaged before installation!
- During the normal running of the inverter, the temperature of the chassis and radiator is relatively high. Please do not install the inverter in crowded places or places where there are easily accessible to non-professional personnel!

2.3.1 Installation Tools

SN	Item	SN	Item	SN	Item
①	Guarded blade utility knife	②	Measuring tape or level	③	Marker
④	Electric drill (drill bit at $\Phi 12/\Phi 14$)	⑤	M6 hex key	⑥	Phillips screwdrivers: M3, M4, M5, M6, and M8
⑦	M8 and M10 outer hexagon socket wrenches	⑧	Diagonal pliers	⑨	Wire stripper
⑩	Crimping tool (H4TC0001)	⑪	DC interconnection terminal removal wrench (H4TC0001)	⑫	Multimeter (range $\geq 1100V$)
⑬	Crimping pliers (output cable terminals and others)	⑭	Heat shrinkable tube and insulation tape	⑮	Heat gun

Note:

Operators need to prepare own insulation shoes, insulation gloves, dust masks and protective goggles.

2.3.2 Installation Environment Requirements

- The protection level of the inverter is IP66, and it can be installed indoors or outdoors. It is recommended to be installed in a place with shelters that can avoid direct sunlight. The shelters can be directly behind the PV panel or under the eaves.

- The inverter should be installed in a well-ventilated place to prevent its performance from being affected by poor heat dissipation.
- When the inverter is running, the surface (especially the radiator part) has a high temperature. Please install it in a place where there is not easily accessible. Please keep it away from children and special group of people.
- The installation area of the inverter should be far away from flammable and explosive materials, and there should be no equipment that generates strong electric interference.
- The mounting rack or wall of the inverter should be able to resist fire at a certain grade.

2.3.3 Installation Angle

When installing the inverter, try to make it perpendicular to the ground and install it in the forward direction. If there is an inclination angle, ensure that the inclination angle and inclination direction meet the installation requirements.

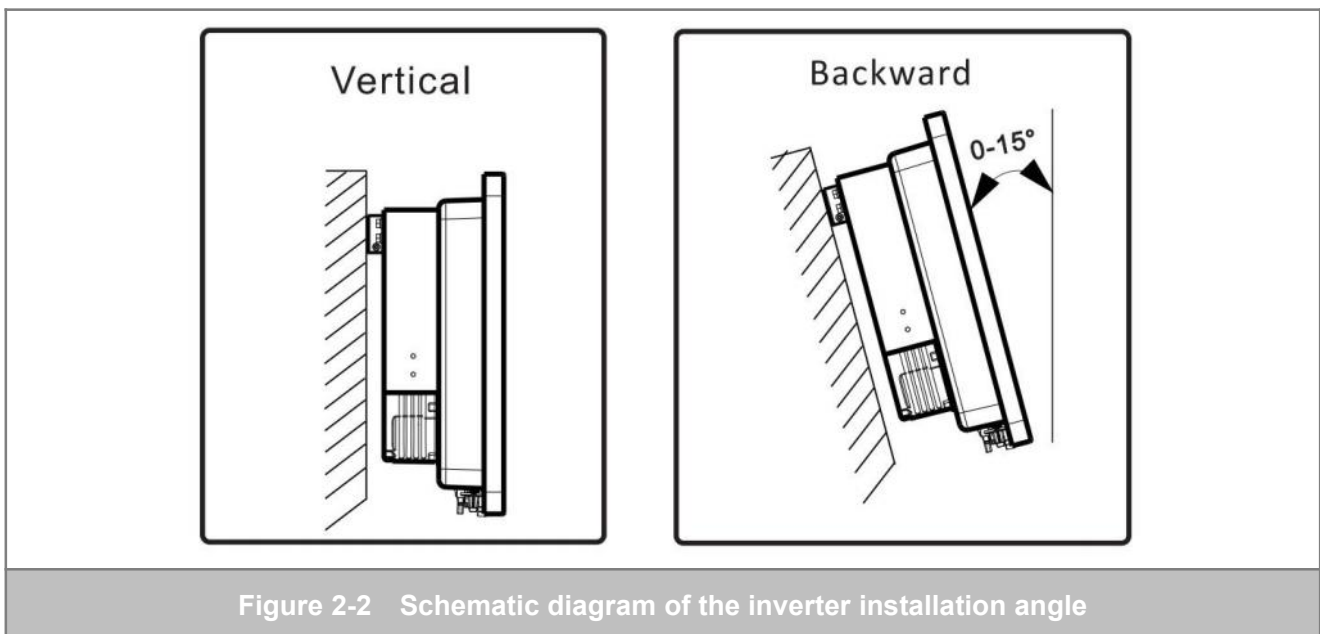

Note:

1. It is recommended to install the equipment vertically or with a caster angle of 15°. Equipment failure due to non-conforming installation is not covered by the product warranty.
2. When installing the equipment, ensure that the radiator is free from obstructions to ensure unobstructed air ducts.

2.3.4 Installation Space

2.3.4.1 Single Inverter Installation

When installing a single inverter, reserve sufficient space around the equipment to facilitate the installation, maintenance and heat dissipation of the inverter. It is recommended that the distance between the bottom of the inverter and the ground be greater than or equal to 600mm after installation. Figure 2-3 shows the installation space of a single inverter.

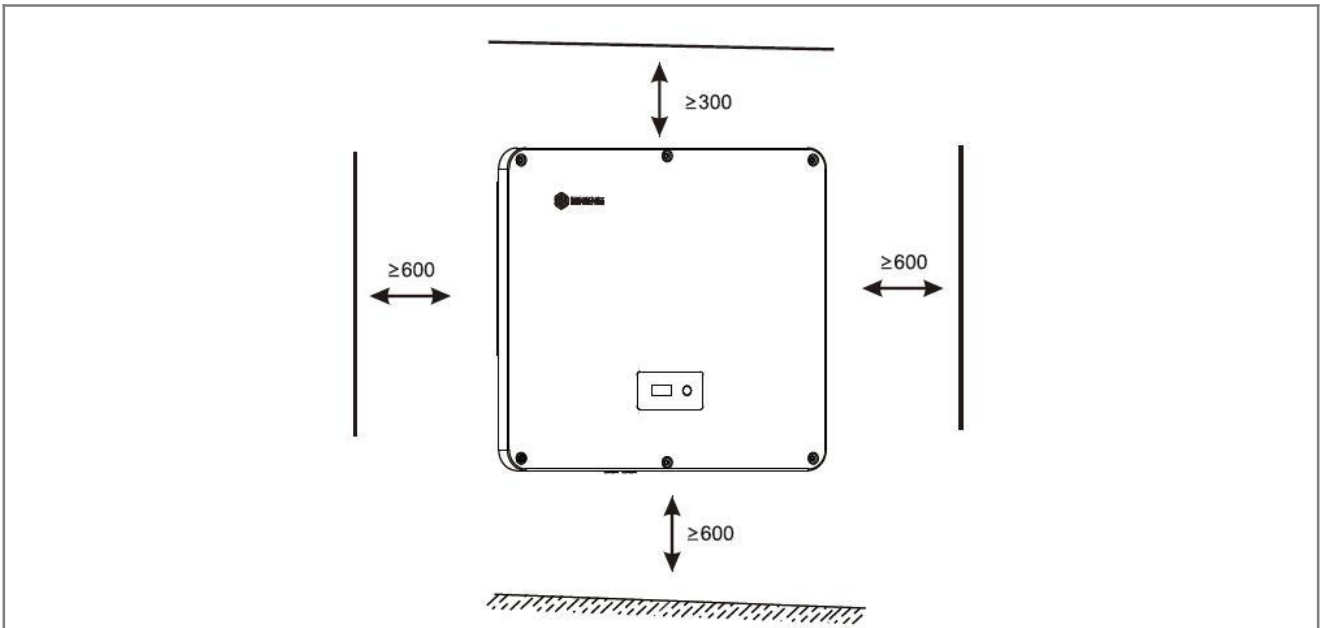

Figure 2-3 Schematic diagram of the installation space for a single inverter

2.3.4.2 Multiple Inverter Installation

To ensure good heat dissipation and easy maintenance of the inverters, leave a proper distance between inverters. Generally, multiple inverters can be installed in a single-row side-by-side mode or multi-row staggered mode. This section describes the specific installation requirements.

- Single-row side-by-side installation

In this installation mode, the distance between the inverters should not be less than 600mm, as shown in Figure 2-4. The distance between the inverter and the upper, lower, left, and right objects (such as walls) must meet the space requirements of single inverter installation, as shown in Figure 2-3.

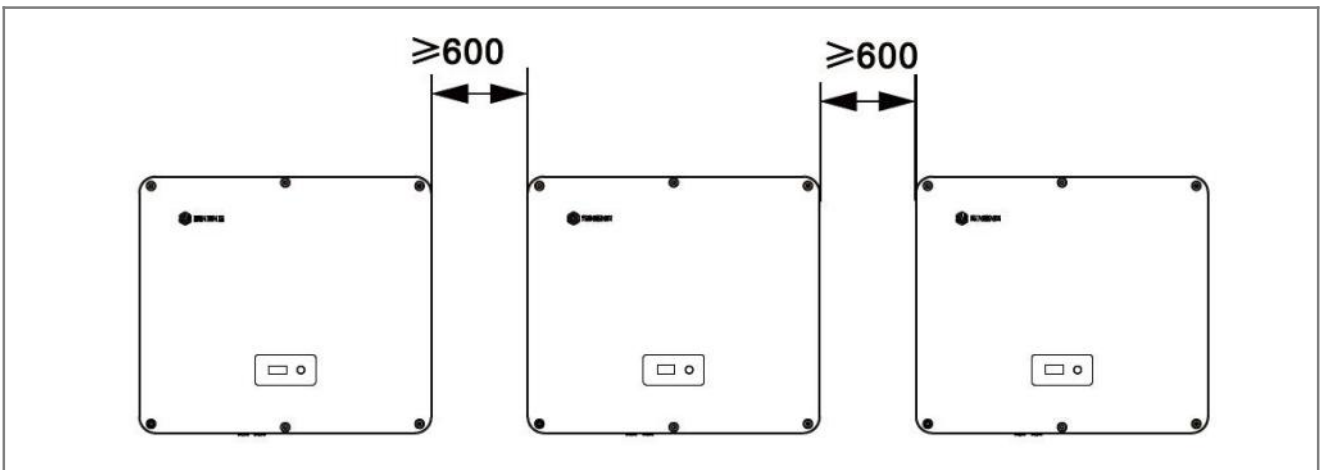

Figure 2-4 Schematic diagram of single-row side-by-side installation mode (unit: mm)

- Multi-row staggered installation

When installing multiple rows of inverters, to facilitate the heat dissipation of the inverters, two adjacent rows of inverters are not allowed to cross in the upper and lower spaces. The lateral distance of the staggered inverters should not be less than 300mm, and the row spacing should not be less than 300mm, as shown in Figure 2-5. The distance between the inverter and the upper, lower, left, and right objects (such as walls) must meet the space

requirements of single inverter installation, as shown in Figure 2-3.

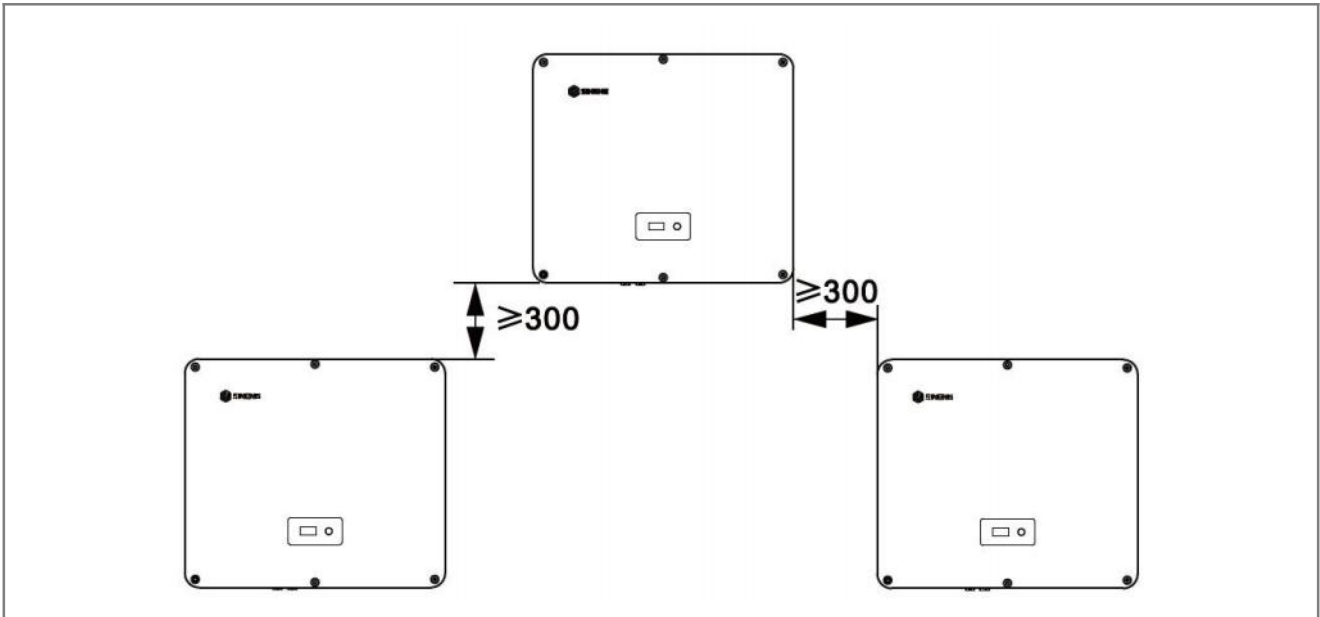

Figure 2-5 Schematic diagram of multi-row staggered installation mode (unit: mm)

2.3.5 Installation Requirements

2.3.5.1 Drawing of Inverter Installation Dimensions

Figure 2-6 shows the backplane dimensions of the inverter.

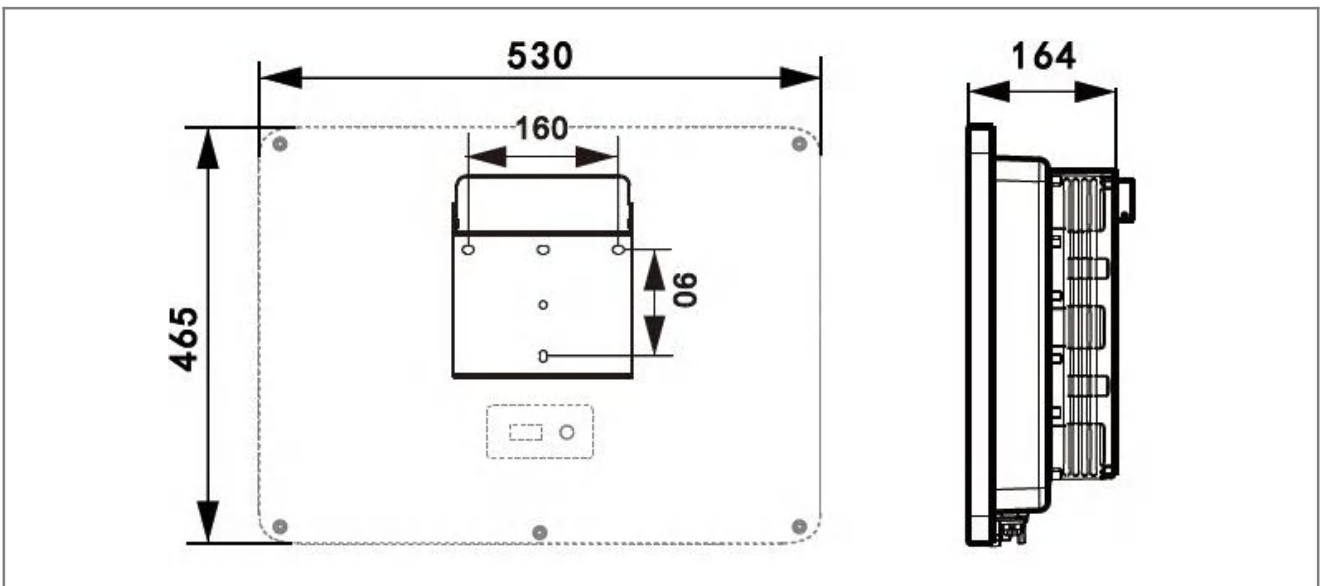

Figure 2-6 Backplane dimensions (unit: mm)

2.3.5.2 Wall-mounted mode

Figure 2-7 shows the installation process of the backplane of the inverter. Take the backplane (or according to the dimensions of the backplane) measure the positions of the mounting holes on the bracket, and mark them with a marker. Install the expansion tube and attach the backplate to the wall with self-tapping screws, and hang the inverter on the backplane. Fix the M4 screws on the side. At this moment, the installation is completed.

Step 1: Determine the punching position according to the inverter installation dimensions drawing shown in

Figure 2-7. Measure the dimensions using a level, and mark the puncturing area using a marker.

Step 2: Use an impact drill to drill a hole with a diameter of $\phi 6$ and depth of 70mm.

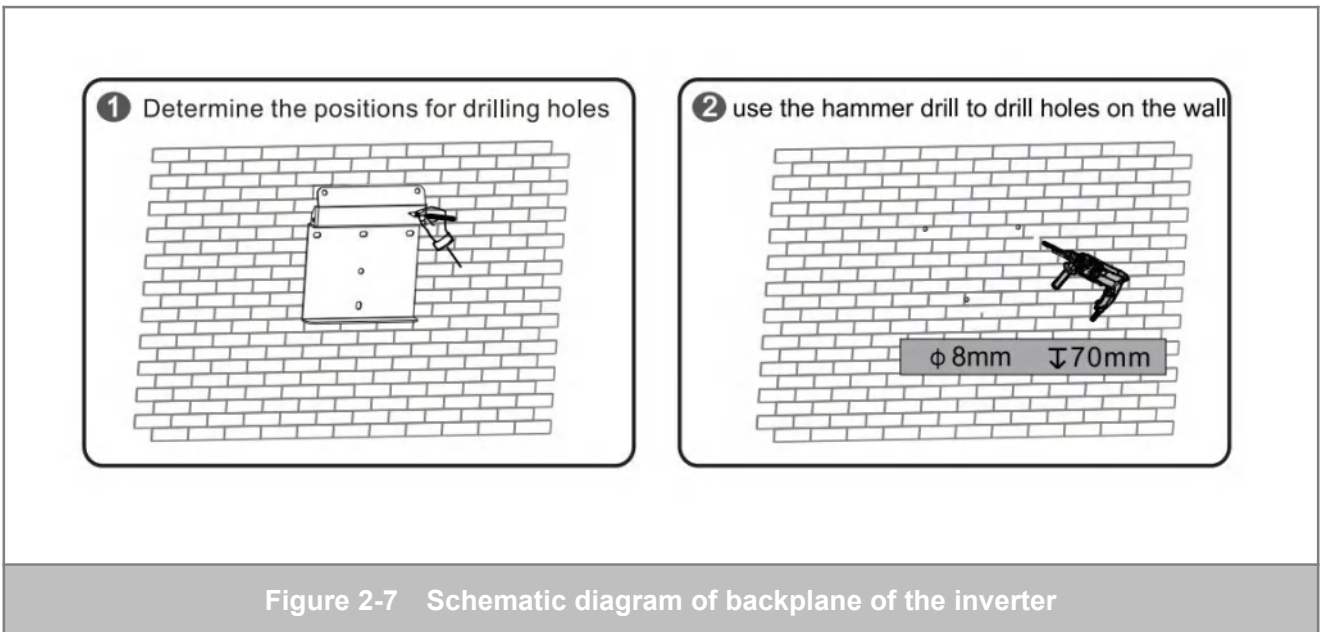

Step 3: Install the expansion tube.

Step 4: Attach the backplate to the wall with self-tapping screws

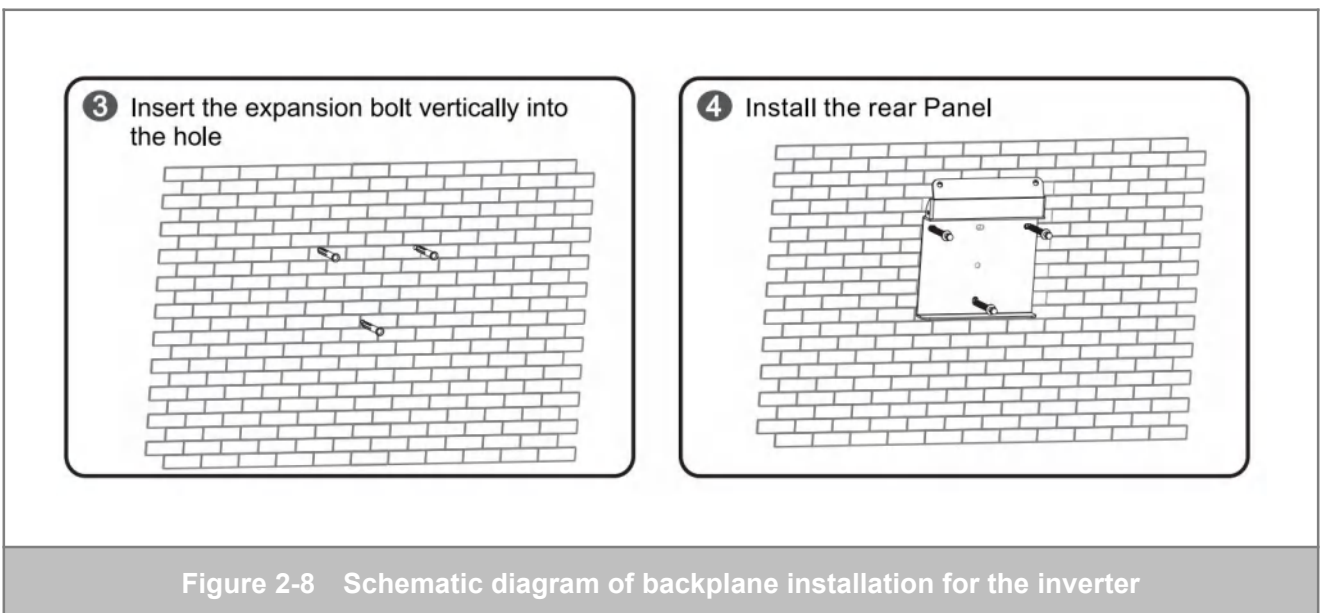

Step 5: Hang the inverter on the backplane.

Step 6: Fix one M4 screw on the right side of the backplane. The installation is completed.

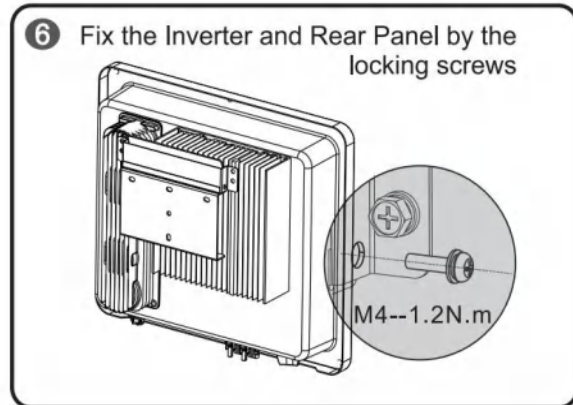
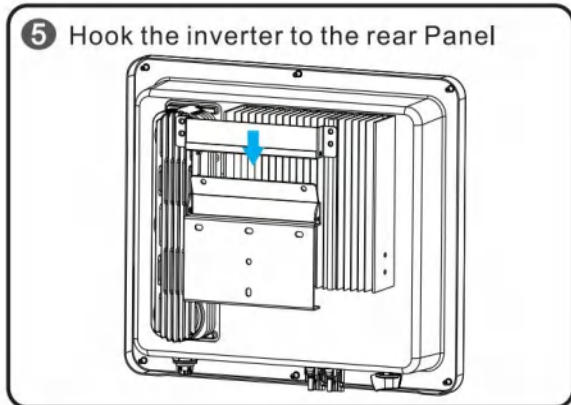

Figure 2-9 Installing the backpanel of the inverter

Note:

1. Pay attention to personal safety when handling the equipment.
2. The accessory package of the product includes expansion tube and self-tapping screws.
3. If the bracket installation method is used on site, prepare M6 combined bolts independently.
4. For the hook-mounted mode, prepare U-steel and U-shaped bolts independently.
5. The bearing capacity of the wall or bracket is equal to or higher than 100kg.

Chapter3 Electrical Connections



Danger

- When there is light, a DC high voltage endangering the personal safety of the operator exists at the PV panel port!
- The insulation layer of the power cable must be intact and free from damages and scratches. Otherwise, it may cause short circuit and fire!
- Before cabling the inverter, check and confirm that all connection cables of the equipment have no dangerous voltage. Obvious warning signs must be set for the external power distribution switches of the equipment to avoid misoperation of the external switches, which will endanger the personal safety of the operator!
- Before wiring, ensure that the AC wiring port is disconnected from the power grid and the AC port has no voltage!



Warning

- Strictly follow the indications on the labels inside the inverter to connect the cables. Otherwise, it will cause damage to the equipment.
- The cable connections of the inverter must be safe and reliable. Cable selection and tightening torque must comply with the requirements of this manual. Otherwise, it may cause fire and damage to the inverter.
- It is prohibited to open the upper cover without permissions. If the tamper-proof label is torn and the inverter is damaged, it will not be covered by the product warranty.
- When the operator opens the upper cover of the wiring compartment, please pay attention to the foaming of the protective upper cover, do not scratch or damage it, otherwise it will cause the inverter to enter the water.
- Please try not to open the inverter wiring compartment in rainy and snowy weather to avoid the risk of water entering.

The external cables of the SN series PV inverters include DC input cables, AC output cables, communication cables, and ground cables. Table 3-1 lists the cables and functions. Table 3-2 lists the cables that need to be prepared by customers.

Classification of Cables Operated by User	Description	Remarks
Ground cable	Ground cable	Connecting to the nearest ground point
AC output cable	Connecting the AC combiner box and the AC output side of the inverter	Outdoor multi-core cable
DC input cable	Connecting the PV panel and the DC input side of the inverter	PV cable in compliance with 1100 V standard
Communication cable	Communication signal cable	Outdoor multi-core cable

Table 3-1 List of cables

Category of Cable	Conductor Properties	Conductor cross-sectional area	Outer Diameter of Cable	Terminal Specifications	Fastening Torque
Ground cable	Outdoor copper core cable	4~6mm ² 4-6mm ²	\	M6 OT terminal: M6	5 N.m 5 N.m
AC output cable	Outdoor copper core cable (5-core)	4~6 mm ² 4-6mm ²	12~18mm 12-18mm	\	1.5N.m 1.5N.m
DC input cable	PV cable in compliance with 1100V standards	4~6 mm ² 4-6mm ²	12~18mm 12-18mm	\	\
Communication cable	Multi-core cable (AWG22-AWG24)	0.2~0.4 mm ² 0.2-0.4 mm ²	8~14 mm 8-14 mm	\	0.5N.m 0.5N.m

Table 3-2 Recommended cable specifications

3.1 Connecting the Ground Cable



Warning

- The inverter must be grounded reliably. Otherwise, it may cause personal injury or abnormal operation of the inverter!

The inverter should be grounded in the shortest path. The procedure for connecting the protective ground cable is as follows:

- (1) Strip a section of bare copper core of the ground cable in the corresponding specifications using the wire stripper. Ensure that the length of the bare copper core is 3 mm longer than that of the OT terminal.
- (2) Cover the OT terminal with a heat shrinkable tube in a suitable size. It is recommended that the length of the heat shrinkable tube (withstand voltage $\geq 600V$) be 1.5-2 times the length of the terminal.
- (3) Crimp the OT terminal to the bare copper core using the crimping pliers.
- (4) Blow the heat shrinkable tube tightly using the heat gun to wrap the terminal and cable tightly. At this time, the cable is completely made (the cable making process is shown in Figure 3-1 ①).
- (5) Fasten the OT terminal of the ground cable to the ground interface with M6 screws, with a fastening torque of 5 N.m (For more information, see Figure 3-1 ②).

Remarks: After the ground terminal is fastened, it is recommended to apply silicone or outdoor paint on the outside of the terminal to improve the anti-corrosion capability of the terminal.

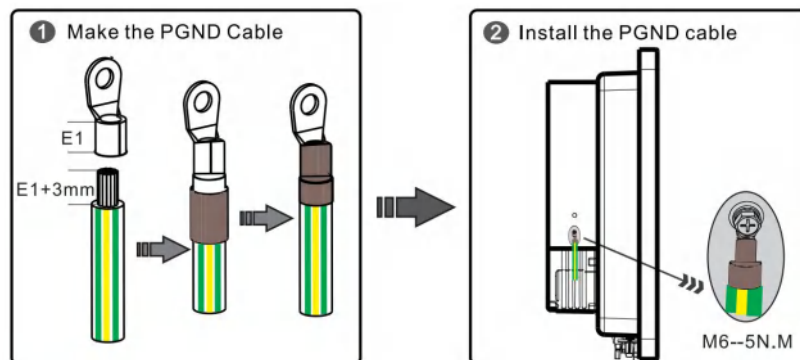

Figure 3-1 Schematic diagram of cable making (OT terminal)

Note:

1. You need to independently prepare OT terminal, cable and heat shrinkable tube used for the protective ground cable.
2. You need to prepare other tools, including diagonal pliers, wire stripper, crimping pliers, heat gun, and M6 Phillips screwdriver.

3.2 Connecting the AC Cable



Warning

- *An AC circuit breaker that matches the power of the inverter must be connected between the inverter output and the power grid, and each inverter must be equipped with an independent circuit breaker!*
- *The tapered end and fastening screw of the AC cable must be tightened. Otherwise, there is a risk of damage to the inverter or fire hazard!*
- *When connecting the AC cable, ensure that the AC circuit breaker is disconnected!*
- *It is prohibited to connect any load between the inverter and the AC circuit breaker!*

3.2.1 AC Circuit Breaker Selection

To ensure that the SN series inverter is normally disconnected from the power grid under abnormal conditions, please select a suitable AC circuit breaker. Table 3-3 lists the recommended specifications.

Inverter Model	Recommended AC Circuit Breaker Specifications
SN12PT	32A
SN10PT	32A
SN8.0PT	32A
SN6.0PT	16A
SN5.0PT	16A
SN4.0PT	16A
SN3.0PT	16A

Table 3-3 Recommended AC circuit breaker specifications

SN series inverter integrates a leakage current protection circuit. When the leakage current is higher than the protection value stipulated in safety regulations, the inverter automatically disconnects from the power grid. If the AC circuit breaker has a leakage current detection function, please select the appropriate equipment according to Table 3-4.

Inverter Model	Trigger Value of Leakage Current
SN12PT	300mA
SN10PT	
SN8.0PT	
SN6.0PT	
SN5.0PT	
SN4.0PT	
SN3.0PT	

Table 3-4 Recommended leakage current protection equipment specifications

3.2.2 AC Cable Connection

Select appropriate AC cables based on application scenarios. The following table lists the recommended cables.

Application Scenario	Recommended Cable
The chassis housing is grounded and there is no neutral cable.	Three-core cable (L1, L2, and L3)
The compartment housing is grounded and there is no neutral cable.	Four-core cable (L1, L2, L3, and PE)
The chassis housing is grounded and there is a neutral cable.	Four-core cable (L1, L2, L3, and N)
The compartment housing is grounded and there is a neutral cable.	Five-core cable (L1, L2, L3, N, and PE)

Table 3-5 Recommended AC cables

SN series inverter supports the phase sequence self-adaptation. The specific procedure for connecting the cables is as follows:

- (1) Make an AC cable and strip it as shown in step ① in Figure 3-2.
- (2) The AC cables are inserted into the AC connectors in sequence.
- (3) Use a hexagonal wrench to fix the AC cable, the recommended torque is 1.5N.m.
- (4) Insert the AC connector, and pull down the buckle to lock it (as shown in step ④).

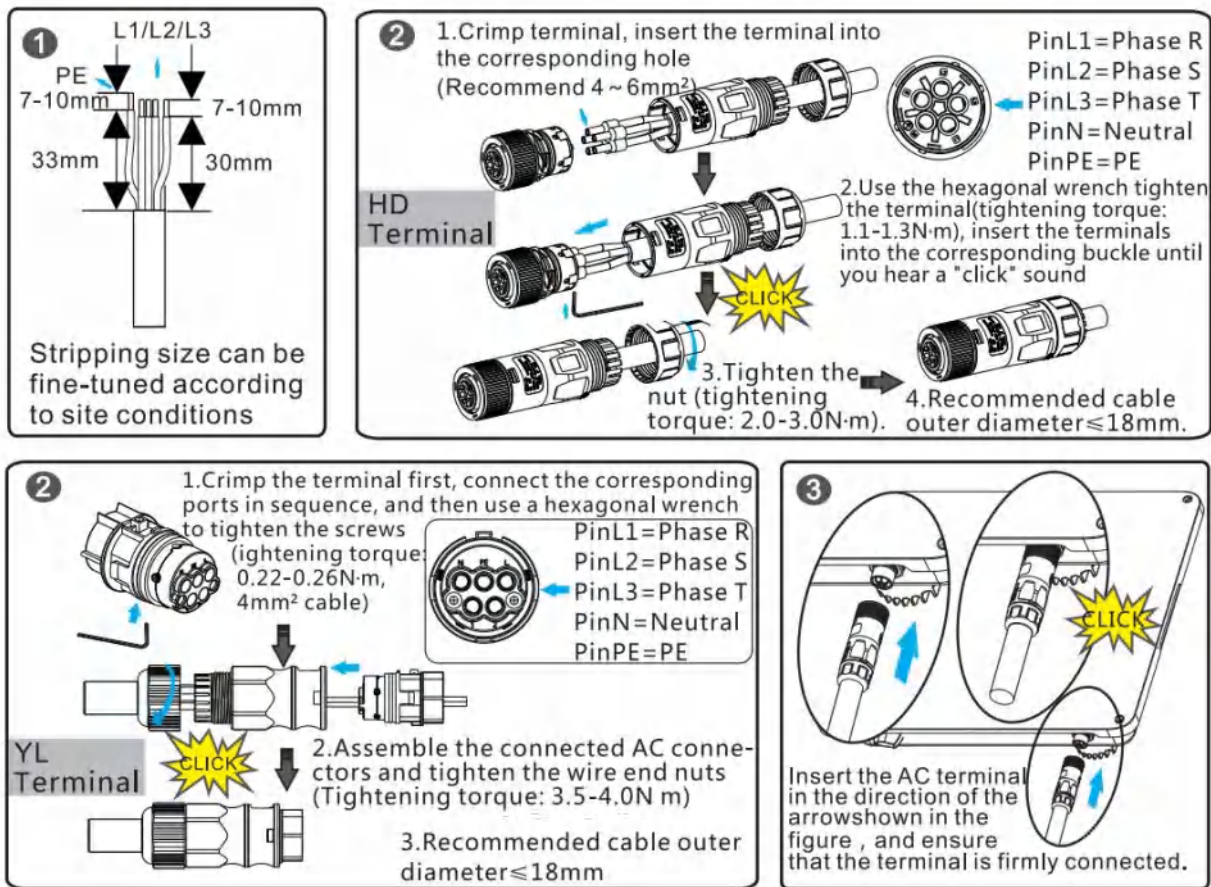

Figure 3-2 Schematic diagram of AC cable installation

Note:

1. Before connecting the AC output cable, disconnect the circuit breaker between the power grid and the inverter.
2. Make sure that the protective layer of the AC output cable is inside the connector, otherwise it will reduce the sealing level at the AC terminals.
3. When fixing the AC cable, make sure that the wire core is completely inserted into the AC wiring hole, there is no leakage, and it is fastened according to the specified torque.

3.3 Connecting the DC Cable



Warning

- *When there is light, the PV panel outputs high voltage, which endangers the life of operator!*
- *Before cabling, ensure that the battery board is completely shielded by an opaque cloth.*
- *The DC switch of the inverter must be in the "OFF" state!*
- *The parameter configuration of the PV panel string should be consistent with the configuration of the DC input parameters of the inverter.*
- *If the inverter is directly connected to the power grid, the positive and negative electrodes of the PV panel cannot be directly grounded.*
- *The positive and negative poles of the battery board cannot be short-circuited to the ground. Otherwise, it may cause equipment damage during the operation of the inverter. The damage to the equipment caused by violations of these precautions is not covered by the warranty.*
- *It is prohibited to use DC terminals with specifications, models and brands not specified by Sineng!*
- *Before connecting the PV string to the inverter, ensure that the PV string is well insulated from the ground.*
- *To increase the power generation capacity of the system, it is recommended that each string be connected to the same number of PV strings with the same specifications and the orientation!*

There are a total of 2 PV inputs on the SN12PT DC side. When shipped, each terminal is provided with a dust plug (as shown in Figure 3-3) to ensure that the inverter can reach IP66 protection rating.

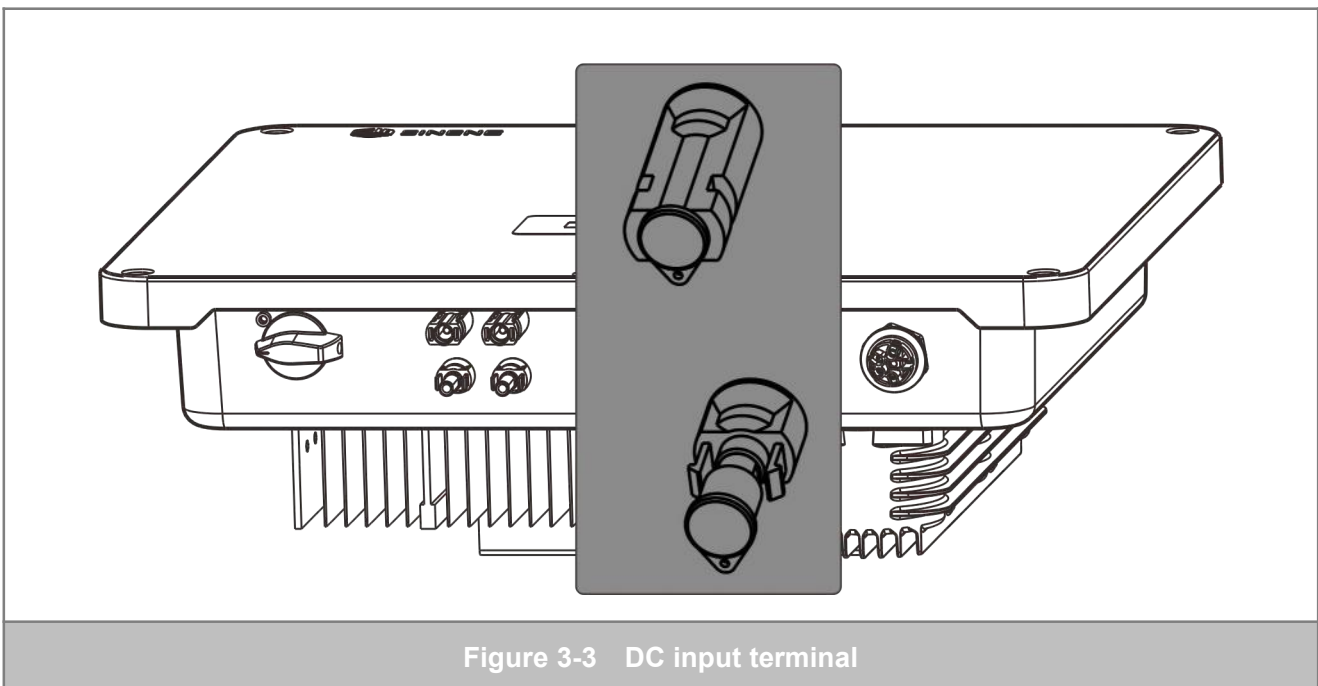
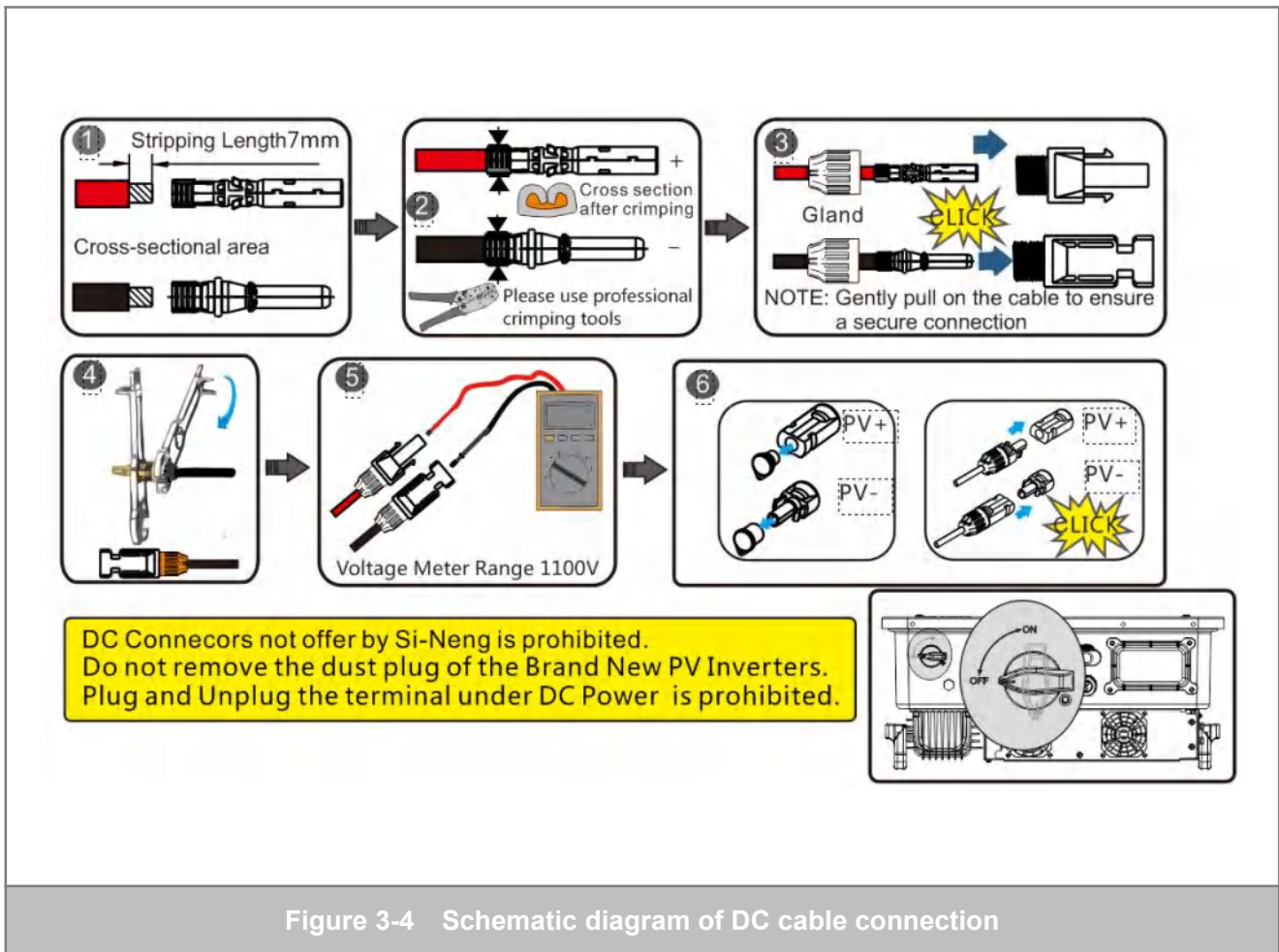

Figure 3-3 DC input terminal

The DC side adopts the dedicated PV interconnection terminal. The procedure for connecting the DC cable is as follows:

- (1) Strip the positive and negative cable insulation skins to a suitable length using a wire stripper, put the cables into the corresponding metallic terminals, and crimp them tightly using a crimping tool.
- (2) Insert the crimped positive and negative cables into the corresponding insulation housing respectively until you hear a click, indicating that they are installed in place.
- (3) Rotate to tighten the plastic nuts at the end of the insulation housing of the positive and negative connectors.
- (4) Measure the voltage of the positive and negative DC terminals using the multimeter to ensure that the polarity of the PV panel is correct, and ensure that the voltage is lower than the maximum input voltage that the system can withstand.

- (5) Remove the dust-proof plug from the DC input side, and insert the positive and negative connectors into the positive and negative electrodes of the DC input terminal of the inverter until you hear a "click", indicating that the connectors are installed in place.



Note:

1. After the positive and negative terminals are inserted into the insulation housing, gently pull them to check for insecure or loose connections.
2. When using a multimeter to measure the voltage, if the measured value is negative, the polarity of the DC input is incorrect. Please correct the polarity.
3. When using a multimeter to measure the voltage, if the measured value is larger than 1100 V, the voltage exceeds the inverter working voltage range. Please re-configure the equipment.

3.4 Installing the Communication Module

 **Warning**

- Please install the communication module strictly according to the User Manual!

The following figure shows the process of installing the 4G data collector.

- (1) Before installation, read the data collector user manual carefully.
- (2) Unscrew the dust cover of the aviation plug, interconnect the data collector with the aviation plug, and tighten the plastic nut clockwise.

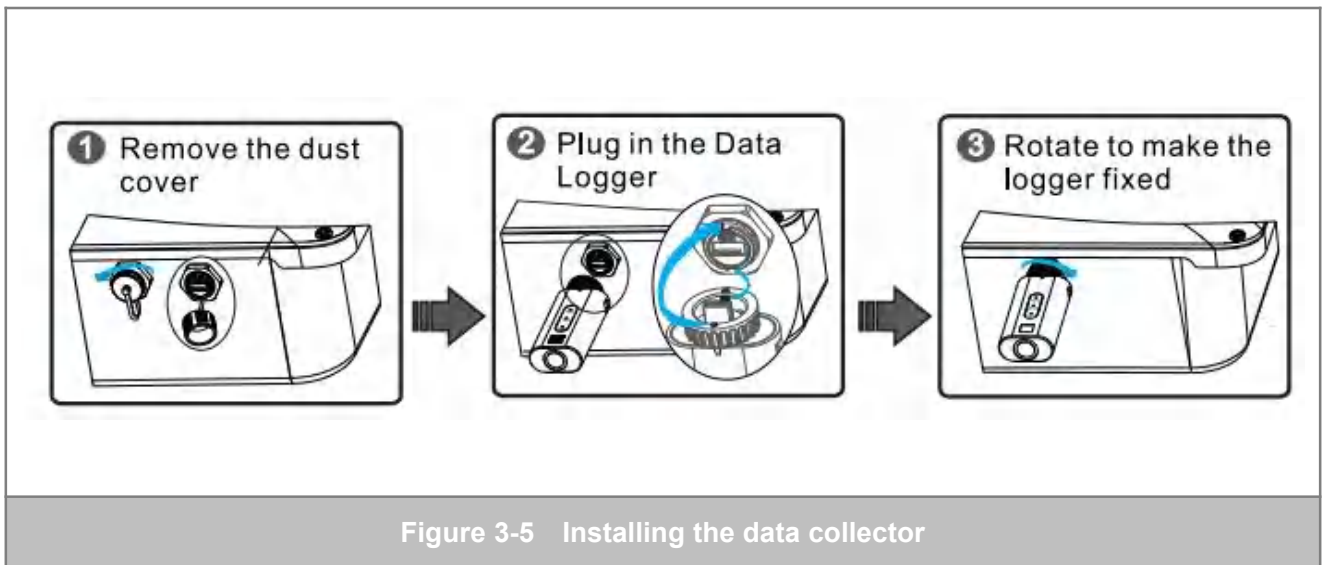

Figure 3-5 Installing the data collector

Note:

1. This step is only for scenarios where the data collector is configured. Figure 3-5 shows the installation method.
2. When installing the data collector, face three indicators outward.
3. When installing data collector, do not rotate the data collector. Otherwise, it will cause the terminals on the board to become loose and cause water to enter the inverter.
4. When installing the data collector, tighten the plastic nut clockwise. Otherwise, there is a risk of abnormal communication or water entry.

3.5 Installing the Communication Cable



Warning

- Please strictly follow the indication on the labels of the inverter communication ports to connect the communication cable!

Table 3-6 describes the definition of communication signals.

SN	Description	Function	SN	Description	Function
1	485_1A	485_1 differential +, used for data collection or inverter cascade	2	485_1A	485_1 differential +, used for data collection or inverter cascade
3	485_1B	485_1 differential -, used for data collection or inverter cascade	4	485_1B	485_1 differential -, used for data collection or inverter cascade
5	PE	Ground the shield layer	6	PE	Ground the shield layer
7	485_2A	485_2 differential +, used for anti-reverse current connection to the power meter in	8	MO	Dry contact

SN	Description	Function	SN	Description	Function
		multi-equipment cascaded scenario			
9	M1	Dry contact	10	M2	Dry contact
11	M3	Dry contact	12	485_2B	485_2 differential -, used for anti-reverse current connection to the power meter in multi-equipment cascaded scenario
13	DRM_GND		14	M4	Dry contact
15	DO	Dry contact	16	DO_GND	

Table 3-6 Definition of communication signals

The procedure for connecting the communication cable is as follows:

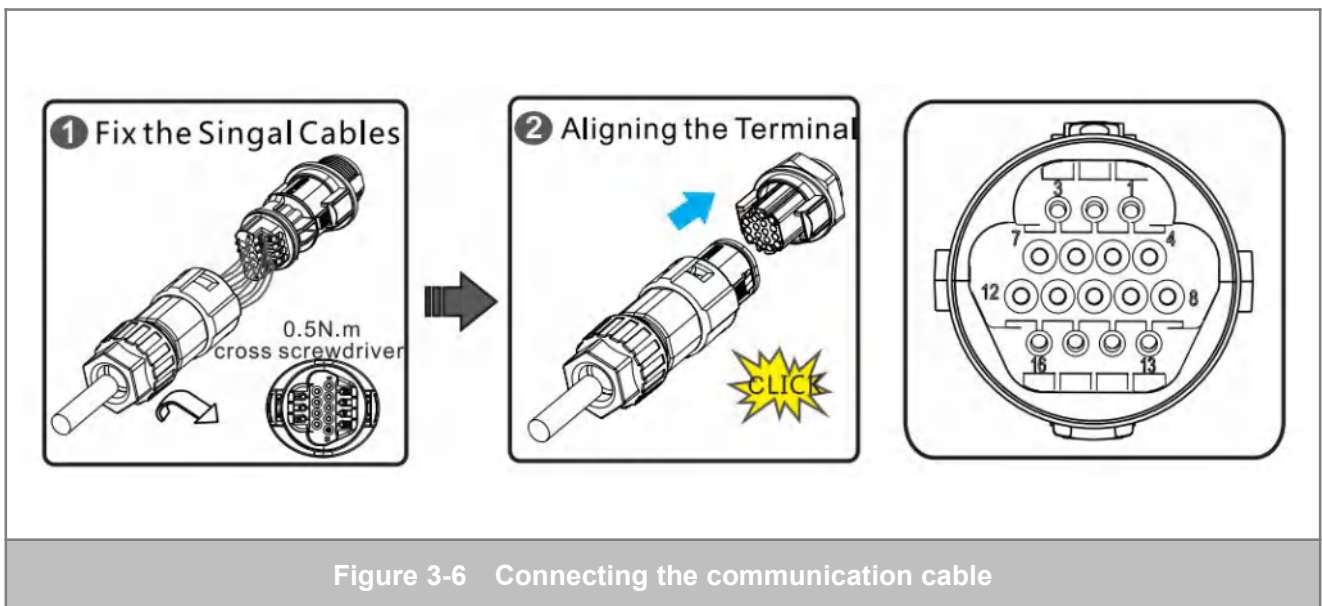

Figure 3-6 Connecting the communication cable

Note:

1. Before connecting the AC output cable, disconnect the circuit breaker between the grid and the inverter;
2. Make sure that the protective layer of the AC output cable is inside the connector, otherwise the sealing level at the AC terminals will be reduced;
3. When fixing the AC cable, make sure that the wire core is completely inserted into the AC wiring hole, there is no leakage, and it is fastened according to the specified torque.

3.6 Inspection after Installation

SN	Check Item	Inspection Result (Yes ✓/No ×)
1	Check whether the DC side switch is in the "OFF" state.	<input type="checkbox"/>
2	Check whether the inverter is installed firmly, and whether the screws on both sides of the backplane are fastened.	<input type="checkbox"/>
3	Check whether the external ground cable is connected correctly, whether the terminal is fastened, whether the grounding is reliable, and whether there is no open circuit or short circuit.	<input type="checkbox"/>
4	Check whether the AC output cable is connected correctly, whether the terminal is fastened, and whether there is no open circuit or short circuit.	<input type="checkbox"/>
5	Check whether the polarity of the DC input cable is correct, whether negative and positive polarities are firmly interconnected, and whether there is no open circuit or short circuit.	<input type="checkbox"/>
6	Check whether the communication cable is connected correctly, whether the terminal is fastened, and whether there is no open circuit or short circuit.	<input type="checkbox"/>
7	Check whether the plastic screw caps at the ends of the AC cable and the communication cable lock are tightened.	<input type="checkbox"/>
8	Check whether the unused interfaces are equipped with dust plugs.	<input type="checkbox"/>
9	Check whether the data collector is properly installed. (Only for products configured with data collectors)	<input type="checkbox"/>

Chapter 4 Inverter Operations



- *Non-professional personnel are prohibited to open the front panel of the inverter, as there is a high voltage risk!*
 - *When the inverter is running normally, there is dangerous voltage inside the equipment! Please operate the inverter in strict accordance with the instructions in this manual!*
 - *Only professional personnel are allowed to operate the inverter. Others cannot operate it without authorization!*
-

4.1 Power-On/Off Operations

4.1.1 Power-On Operation

- (1) Before initial power-on of the inverter, check whether the following requirements are satisfied:
- (2) Ensure that the installation site environment of the inverter meets the relevant requirements in Chapter 2 of this manual.
- (3) Ensure that the connection of input and output power cables, signal cables, and ground cables meet the requirements specified in Chapter 3 of this manual.
- (4) Ensure that the circuit breaker of the combiner box connected to the AC side of the inverter is in the open state.
- (5) Check the positive and negative polarities of the DC input cables and ensure that the phase sequence of the AC output cables meets the requirements specified in Chapter 3 of this manual.
- (6) Rotate the DC Switch to the "OFF" position.
- (7) Before connecting the equipment to the power grid, measure the voltage and frequency of the grid-connected access point to ensure that the grid-connected specifications of the inverter meet the requirements specified in Chapter 6 of this manual.

After the preceding conditions are satisfied, power on the equipment in the following steps:

Close the circuit breaker connected to the inverter in the AC combiner box.

- (1) Rotate the DC switch to the "ON" position.
- (2) Establish a connection with the inverter through RS485 communication or other communication methods. If there is no fault or alarm information, the inverter automatically starts up and connects to the grid without human intervention. If there is fault and alarm information about the inverter, address the problem based on the information provided in Chapter 5 or contact Sineng customer service personnel.

4.1.2 Power-Off Operation

Power off the equipment in the following steps:

- (1) Power off the equipment through RS485 or other communication modes.
- (2) Disconnect the circuit breaker connected to the inverter in the AC combiner box.
- (3) Set the DC switch of the inverter to the "OFF" state.

4.2 Cable Disconnection Operation



- *After the inverter is disassembled, wait for 30 minutes until the energy storage components in the inverter complete the discharge!*
- *When maintaining the PV panel, be sure to disconnect the DC switch of the inverter as well as the switch in the corresponding AC combiner box. Otherwise, there is a risk of electric shock!*

Before disconnecting the cables of the inverter, ensure that the inverter is completely powered off. The procedure for disconnecting the cables as follows:

- (1) Disconnect the circuit breaker corresponding to the inverter in the AC combiner box and make a warning sign to prevent misoperation by other personnel!
- (2) Remove the interconnection terminal on the DC side using a special DC tool, as shown in the following figure.

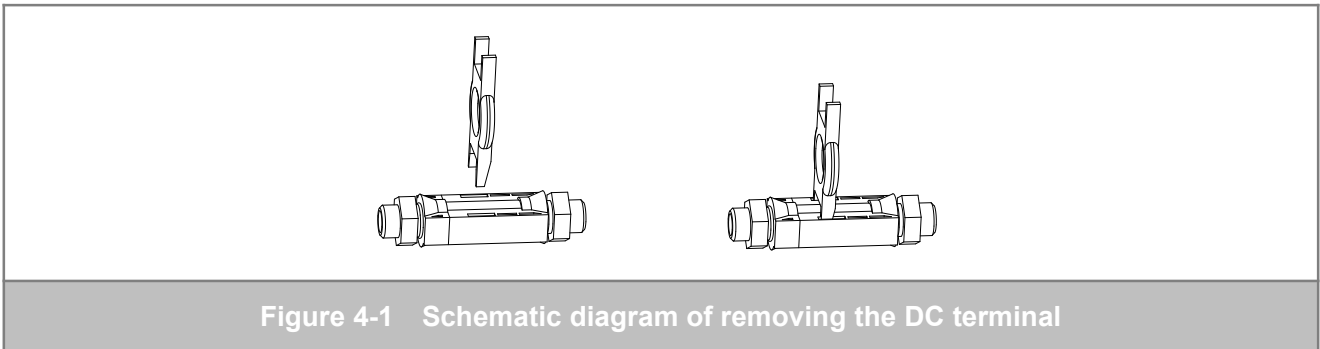

- (1) Remove the waterproof parts with the "AC" sign on the AC side, remove the AC power cable, and properly handle the removed power cable.
- (2) Remove the waterproof parts of the communication port, remove the communication cable, and properly handle the removed communication cable.
- (3) Remove the ground cable.

Chapter 5 Events and Alarms



Warning

- *Non-professional personnel are prohibited to handle inverter alarms or failures!*
- *Please strictly follow the instructions in this menu to handle inverter events!*

5.1 Event Information

Event	Description
Inverter connected to power grid to generate power	When the inverter switches to the grid-connected state, the system displays "Inverter enabled" or "Inverter disabled".
Inverter alarm generated	When the system generates an alarm in the grid-connected state, the system displays "Inverter alarm generated".
Remote power-on	When the inverter is remotely powered on, the system displays "Remote power-on".
Remote power-off	When the inverter is remotely powered off, the system displays "Remote power-off".

Table 5-1 Event information description

5.2 Alarm Information

When the inverter is running, if it encounters a power grid failure, PV panel failure, or inverter status exception, it makes intelligent identification and displays the failure information on the panel or mobile app. The following table lists the failure alarms, description, and handling suggestions.

Alarm ID	Alarm Name	Handling Method
1	Power grid voltage exception	Check the power grid voltage. If the power grid voltage exceeds the allowable range, please seek solutions from the local power company. If the power grid voltage is within the allowable range, please contact Sineng customer service center.
4	Power grid frequency exception	Check the power grid frequency. If the power grid frequency exceeds the allowable range, please seek solutions from the local power company. If the power grid frequency is within the allowable range, please contact Sineng customer service center.
5	No mains	Check the line connection on the AC side after shutdown. Restart the inverter. If the fault information still exists, contact the manufacturer.

Alarm ID	Alarm Name	Handling Method
6	Phase reversed	Check the AC line connection on the output side. After the problem is solved, restart the inverter. If the fault information still exists, contact the manufacturer.
7	GFCI fault	Check the grounding of the lines. Restart the inverter. If the fault information still exists, contact the manufacturer.
8	ISO fault	Check whether the DC cable is reliably grounded. Restart the inverter. If the fault information still exists, contact the manufacturer.
9	DCI fault	Restart the inverter. If the fault information still exists, contact the manufacturer.
10	NPE voltage exception	
21	Equipment is abnormal	Restart the inverter. If the fault information still exists, contact the manufacturer.
23	High temperature	Check the temperature after shutdown. After the problem is solved, restart the inverter. If the fault information still exists, contact the manufacturer.
24	Inconsistent primary and secondary versions.	Restart the inverter. If the fault information still exists, contact the manufacturer.
25	Communication exception	Check the communication cable connection after shutdown. Restart the inverter. If the fault information still exists, contact the manufacturer.
33	Bus over-voltage	
39	AFCI fault	Check the panel cable connection after shutdown. Restart the inverter. If the fault information still exists, contact the manufacturer.
40	PV over-voltage	Disconnect the DC switch and check the PV panel voltage. If the fault information still exists after the voltage resumes normal, contact the manufacturer.
41	PV reversely connected	Check the line connection on the inverter input side. After the problem is solved, restart the inverter. If the fault information still exists, contact the manufacturer.

Table 5-2 List of fault alarms

Chapter 6 Product Specifications

6.1 Application Standards

The inverter design complies with the related standards in China and other countries:

IEC 61000-6-4/IEC 61000-6-2 EMC immunity requirements for inverters

IEC62109-1 General requirements for photovoltaic inverter safety regulations

IEC62109-2 Special requirements for photovoltaic inverter safety regulations

6.2 Conventional parameters

Item	Specification						
Whole equipment model	SN3.0PT	SN4.0PT	SN5.0PT	SN6.0PT	SN8.0PT	SN10PT	SN12PT
Dimensions (mm)	530*465*174						
Net weight (kg)	14.5				15		
Operating temperature	-25~60℃						
Storage temperature	-40~70℃						
Relative humidity	0-100%, non-condensing						
Altitude	4000m (more than 2000m derating)						
Pollution level	Level III						

Table 6-1 Conventional parameters

6.3 Electrical Characteristics (DC Input)

Item	Specification						
Whole equipment model	SN3.0PT	SN4.0PT	SN5.0PT	SN6.0PT	SN8.0PT	SN10PT	SN12PT
Maximum access component power (kWp)	4500	6000	7500	9000	12000	15000	18000
Maximum open-circuit voltage of PV array (Vdc)	1100						
Maximum single-channel input current (Adc)	16						
Startup voltage of inverter (Vdc)	180V						

Item	Specification						
Overvoltage level at the DC input of the equipment	II						
MPPT voltage range (Vdc)	140-1000V						
Number of DC input tributaries	1/1	1/1	1/1	1/1	1/1	1/1	1/1
Number of MPPT tributaries	2	2	2	2	2	2	2
Maximum reverse sink current (A)	25/25						
Table 6-2 DC input							

6.4 Electrical Characteristics (AC Output)

Item	Specification						
Equipment model	SN3.0PT	SN4.0PT	SN5.0PT	SN6.0PT	SN8.0PT	SN10PT	SN12PT
Grid system	3/N/PE						
Rated output power (kW)	3	4	5	6	8	10	12
Maximum output apparent power (kVA)	3.3	4.4	5.5	6.6	8.8	11	13.2
Rated output voltage (Vac)	230/400V						
Output working voltage range	312~485 V (phase voltage of 180~280 V)						
Rated output current (Aac)	4.3	5.8	7.2	8.7	11.6	14.5	17.4
Maximum output current (Aac)	4.8	6.4	8	9.6	12.8	15.9	19.1
Rated frequency (Hz)	50Hz /60Hz						
Overvoltage level of equipment AC output	II						
Total harmonic distortion of output voltage	Total distortion rate <3% (grid THDv≤2%, load≥50%)						
Output power factor	When the load current is higher than 50%: PF>0.99; when the load current is higher than 30% and lower than 50%: PF>0.98; when the load current is lower than 30%, the PF value is not required.						
Output DC component	<0.5%*In (rated current)						
Table 6-3 AC Output							

6.5 Electrical Characteristics (Protection Characteristics)

Item	Specification						
	SN3.OPT	SN4.OPT	SN5.OPT	SN6.OP T	SN8.OP T	SN10PT	SN12PT
Whole equipment model	SN3.OPT	SN4.OPT	SN5.OPT	SN6.OP T	SN8.OP T	SN10PT	SN12PT
DC reverse connection protection	Provided						
Leakage current protection	Provided						
Anti-islanding protection	Provided						
DC switch	Provided						
Detecting ISO	Provided						
String detection	Provided						
Lightning protection	AC/DC surge protector						
PID protection	Optional						

Table 6-4 Protection characteristics

6.6 Electrical Characteristics (System Characteristics)

Item	Specification						
	SN3.OPT	SN4.OPT	SN5.OPT	SN6.OPT	SN8.OPT	SN10PT	SN12PT
Whole equipment model	SN3.OPT	SN4.OPT	SN5.OPT	SN6.OPT	SN8.OPT	SN10PT	SN12PT
Maximum inverter efficiency (%)	98.30					98.50	
EU efficiency(%)	98.00					98.20	
Self-power consumption at night (W)	< 0.5(Night loss <10 after PID is turned on)						
Display and operation UI	LED/OLED (optional)						
Insulation resistance (MΩ)	>10 (1000Vdc)						
Protection rating	IP66						
Cable entry method	Bottom entry						
Cooling method	Natural						

Table 6-5 System Characteristics

Chapter 7 Product Maintenance

This chapter describes inverter maintenance, including inverter maintenance cycle and inverter maintenance methods. Please read the instructions in this chapter carefully before performing inverter maintenance.



- *Only professional personnel are allowed to maintain the inverter. Others cannot maintain it without authorization!*
- *In order to ensure the safety of maintenance personnel, it is prohibited to touch any live parts of the inverter when the inverter is running, and always check whether the ground point of the inverter is reliably connected.*
- *After the inverter is completely powered off, there are still dangerous voltage hazards in the inverter! Wait for 30 minutes before operating the inverter!*
- *When the inverter is working, it is prohibited to plug or unplug the DC connector!*
- *Please use qualified spare parts provided by Sineng only. Sineng shall not assume any liability for the equipment damage due to the use of non-Sineng spare parts.*
- *Unauthorized or non-permitted disassembly of the inverter may cause damage to the equipment. Such equipment damage is not covered by the product warranty!*

7.1 Periodic Maintenance

Periodic inspection and maintenance of the inverter can help you understand the inverter state in a timely manner, thereby improving the reliability of the inverter. Table 7-1 shows the periodic inspection checklist.

Check Item	Method	Inspection Cycle
System cleaning	Check that there are no foreign objects on the radiator and monitor the overall health state of the inverter.	Once a year or when anomaly is detected
Fan	Check whether there is abnormal noise when the fan is running. Check whether the fan blades have cracks. Check whether the fan is blocked by foreign matter. Check whether derating protection is enabled for the fan.	Once every six months
System operating state	Check whether the appearance of the inverter is damaged or deformed.	Once a year
Cable connection	Check whether the AC and DC cables are reliably connected and are intact. Check whether the ground cable is reliably connected.	Half a year after the first commissioning, and once every half a year or once every year thereafter
Tightness	Check that all terminals and connections are well sealed.	Once a year

Table 7-1 Periodic inspection checklist

After-sales Service Information

Sineng Electric Co., Ltd. provides a full range of technical support services for customers. Customers can contact the nearest Sineng local office or customer service center, or directly contact the HQ.

Sineng Electric Co., Ltd.

Address: No.6, Hehui Road, Huishan Economic Development Zone, Wuxi, China

Postal code: 214174

Customer service hotline: 0510-88888118

Fax: 0510-85161899

Warranty Card

Thank you for choosing Sineng PV inverter.

Product model: _____

Delivery No.: _____

Please refer to the instructions in the *User Manual* for specifications, implementation standards, and technical conditions of this product.

This product is guaranteed for _____ year(s). During the warranty period, Sineng will provide free component repair or replacement services for failures caused by non-human reasons and force majeure (including but not limited to earthquakes, mudslides, floods, typhoons, and wars).

User name: _____

User address: _____

Contact person: _____

Phone number of user: _____

Email: _____

Sineng Electric Co., Ltd.

Address: No.6, Hehui Road, Huishan Economic Development Zone, Wuxi, China

Postal code: 214174